



öko skin

slat wall panels made of
glassfibre reinforced concrete

Beton lebt.



RIEDER

As beautiful as wood, as tough as concrete!



Concrete lives. | Glassfibre reinforced concrete is a natural material. The raw materials used for the production of öko skin create a specific surface appearance which is typical for concrete.



Flexible applications | öko skin can be used for large-scale facades as well as for small projects such as porches, conservatories, patios, garden sheds, garages, fences and many more.



Durability | Facades clad with öko skin slat wall panels require minimum maintenance. Unlike wooden claddings, glassfibre reinforced concrete doesn't require sealing or painting.



Easy to install | The slat wall panels have a very convenient size and can be mounted and processed on site - both by professionals and skilled do-it-yourselfers.



Non-combustible | öko skin is totally fire resistant thanks to fire protection class A1 (non-combustible according to DIN 4102) and therefore a safe alternative to traditional wood panelling.



Sustainability | Rieder sets itself high standards in the protection of the environment (ISO 9001 and ISO 14001 standard). The Environmental Product Declaration EPD provides detailed figures on the eco-balance of öko skin.



ö with two dots | ö is a character used in several Latin alphabets. The pronunciation of ö is like „i“ in „Sir“. ö can be transcribed as „oe“ and is a typical character of Austria. The ö of öko skin stands for Österreich (Austria), ökologisch (ecological) and ökonomisch (economical).

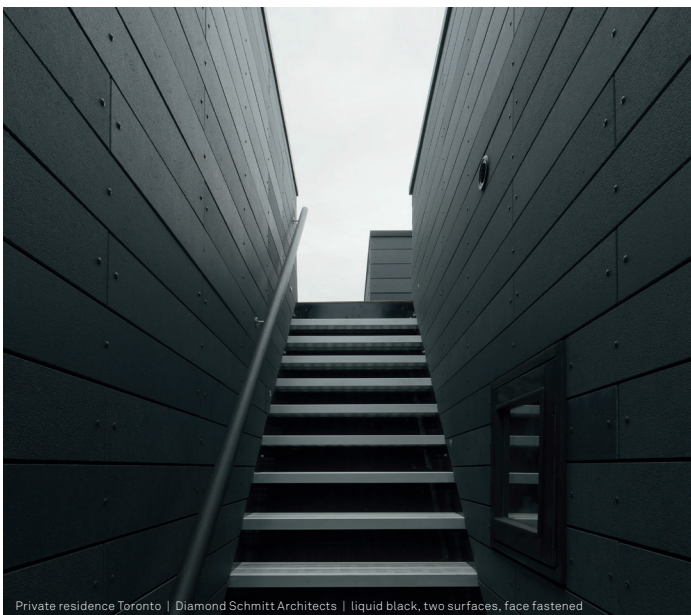

Private residence Toronto | Diamond Schmitt Architects | liquid black, two surfaces, face fastened

Sizes

öko skin standard

147 x 1800 x 13 mm | 5.79" x 70.87" x 1/2"
mix of three surfaces matt, ferro light, ferro



öko skin flex

width from 110 to 302 mm | 4.33" to 11.89" and
length from 700 to 2500 mm | 27.56" to 98.42" on request



The slats can be cut to size and holes can be drilled by the craftsmen directly on site. Edges don't require sealing after cutting the slats.



St Denis Junior Public School, Toronto | Bortolotto Architects | off-white, two surfaces, face fastened

Colors and surfaces

öko skin is through-colored including iron oxide and natural additives. The authentic colors of öko skin fit well in landscapes and blend with nature and the environment. Each palette includes three textures

ferro, ferro light and matt which create a naturally varied and vivid surface. The play of colors within a certain color shade is intentional and enhances the character of concrete.

	polar white**	off-white	ivory	silvergrey*	chrome	anthracite	liquid black**	sahara	sandstone	terra**	terracotta	green
matt												
ferro light												
ferro												

* Discounted color ** Premium colors

Installation

öko skin slat wall panels are used as facade cladding and mounted on a substructure. They can be installed both horizontally and vertically. öko skin slats can be fastened with screws, rivets or adhesive to an aluminium substructure. Screws and rivets are available in color matched finish. öko skin flex 302 mm | 11.89" can be also installed as lap siding.

For further details on processing and mounting please consult our "installation instructions" on www.rieder.cc (refer to country-specific regulations).

Assembly principle: screws on aluminium substructure

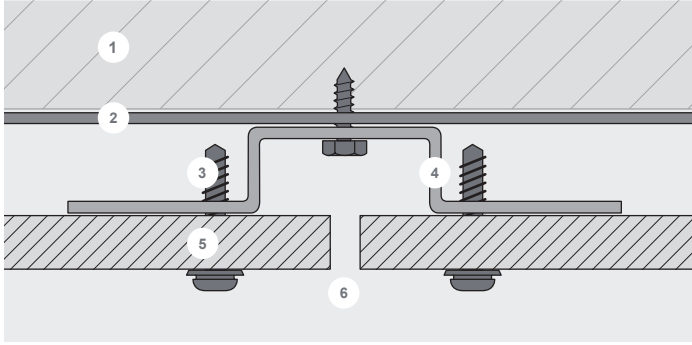

- 1 insulation
- 2 horizontal subgirt support
- 3 screw
- 4 hat channel subgirt
- 5 öko skin slat
- 6 open vertical joint

NEW | Concealed fastening with RPA Rieder Power Anchor



Layout examples



öko skin 147 mm, anthracite, vertical installation (1/3 shifted), screwed on aluminium substructure



öko skin flex 125 mm, terra, horizontal installation (1/2 shifted), screwed on wooden substructure



öko skin flex 147 mm, silvergrey, vertical installation, screwed on wooden substructure



Coming soon!
öko skin 147 mm, anthracite vintage, horizontal installation (1/2 shifted), glued on aluminum substructure



Rieder Sales GmbH

Mühlenweg 22 | 5751 Maishofen | Austria
+43 6542 690 844
office@rieder.cc | www.rieder.cc

Rieder NORAM Inc.

N3840 2nd St | WI 54895 Weyerhaeuser | USA
888-573-8069 (toll free)
sales.usa@rieder.cc | www.rieder.cc